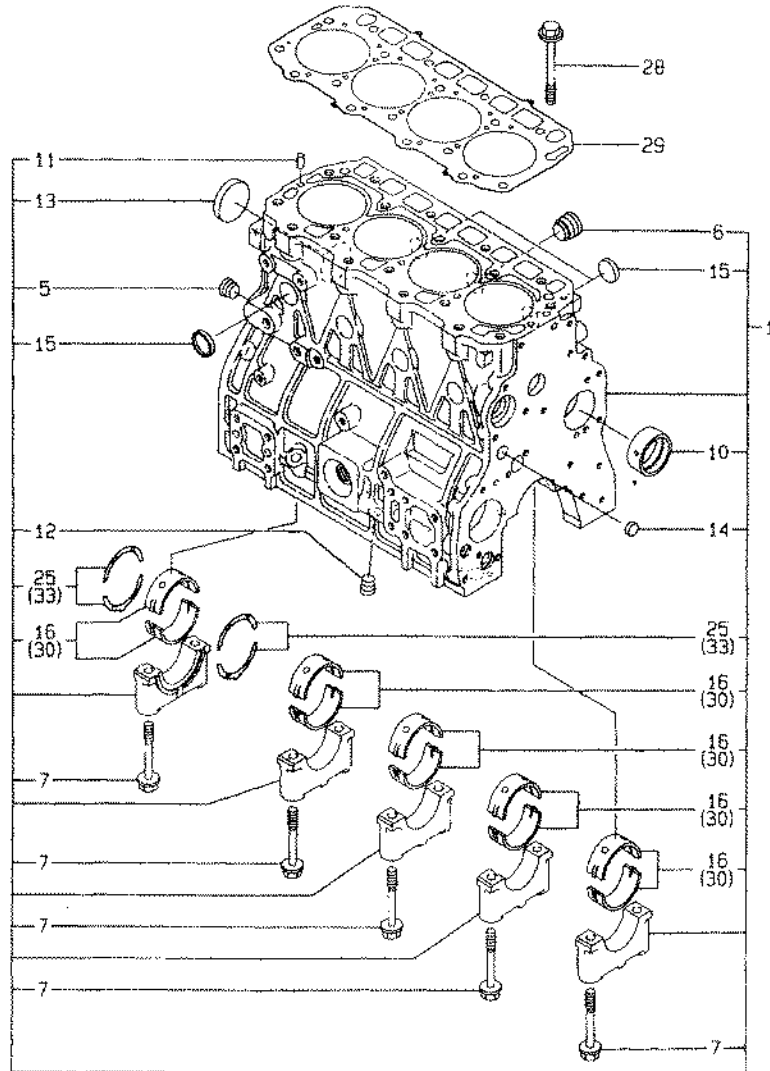

Fig.1.CYLINDER BLOCK

(A)=4TNE98-SA (D)=
 (B)=4TNE98-G1A (E)=
 (C)= (F)=

1, CYLINDER BLOCK



REF	LEV	PARTS NO	DESCRIPTION	QTY						I	R	
				(A)	(B)	(C)	(D)	(E)	(F)			
1	1	729902-01560	BLOCK ASSY, CYLINDER	1	1							
5	2	23871-030000	PLUG PT3/8,SCREW	1	1							
6	2	171051-01921	PLUG	1	1							
7	2	129900-02020	BOLT, METAL CAP	10	10							
10	2	129900-02410	BUSH, CAMSHAFT	1	1							
11	2	22351-060012	SPRING PIN 6X12	2	2							
12	2	23871-030000	PLUG PT3/8,SCREW	1	1							
13	2	27231-550000	PLUG 55	1	1							
14	2	27241-160000	PLUG 16	1	1							
15	2	27241-300000	PLUG 30	8	8							
16	2	129900-02600	BEARING ASSY, MAIN	5	5							
25	2	129900-02930	BEARING ASSY, THRUST	2	2							
28	1	129900-01200	BOLT, HEAD	18	18							
29	1	129902-01330	GASKET,CYL HEAD	1	1							
30	1	129900-02340	MAIN BEARING US=0 25	5	5						1	
33	1	129900-02940	BEARING,THRUST 25OS	2	2							2

Remarks
 (1) UNDER-SIZED(U S=0 25)PART
 (2) OVER-SIZED(O S=0 25)PART

Fig.2.GEAR HOUSING

(A)=4TNE98-SA (D)=
 (B)=4TNE98-G1A (E)=
 (C)= (F)=

2. GEAR HOUSING

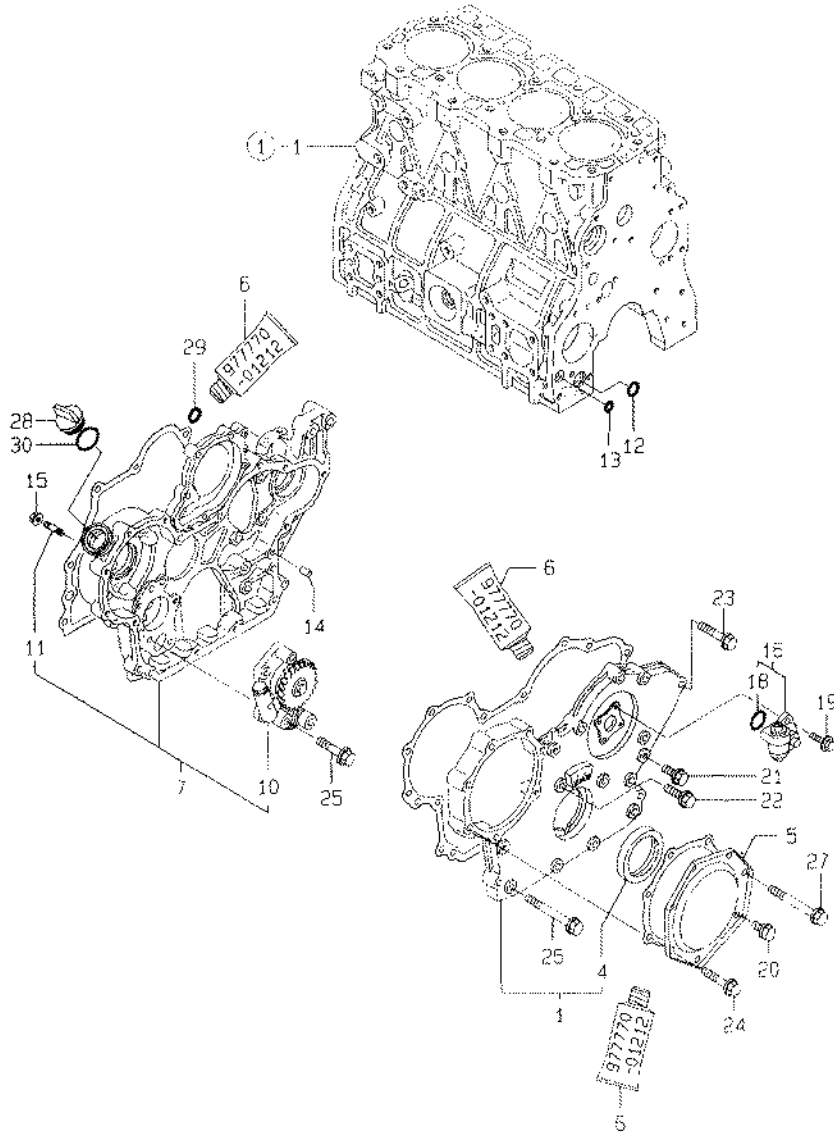

REF	LEV	PARTS NO	DESCRIPTION	QTY						
				(A)	(B)	(C)	(D)	(E)	(F)	
1	1	729900-01570	COVER, GEAR HOUSING	1	1					
4	2	129900-01780	SEAL, OIL	1	1					
5	1	129900-01740	COVER, PUMP	1	1					
6	1	977770-01212	GASKET, LIQUID	1	1					
7	1	129900-01820	HOUSING COMP. GEAR	1	1					
10	2	129900-32000	PUMP ASSY. LUB. OIL	1	1					
11	2	26216-100302	STUD BOLT	4	4					
12	1	129900-32030	O-RING P20	1	1					
13	1	129900-32040	O-RING P14	1	1					
14	1	22312-080160	PARALLEL PIN 8X 16	4	4					
15	1	26366-100002	NUT M10	4	4					
16	1	129150-91400	GEAR UNIT, TACHOMETER	1	1					
18	2	24341-000240	O-RING 1A S-24.0	1	1					
19	1	26106-060162	BOLT M 6X 16 PLATED	2	2					
20	1	26106-080162	BOLT M 8X 16 PLATED	1	1					
21	1	26106-080202	BOLT M 8X 20 PLATED	3	3					
22	1	26106-080302	BOLT M 8X 30 PLATED	1	1					
23	1	26106-080402	BOLT M 8X 40 PLATED	5	5					
24	1	26106-080402	BOLT M 8X 40 PLATED	5	5					
25	1	26106-080452	BOLT M 8X 45 PLATED	3	3					
26	1	26106-080702	BOLT M 8X 70 PLATED	6	6					
27	1	26106-080702	BOLT M 8X 70 PLATED	1	1					
28	1	124160-01751	CAP. LUB OIL SUPPLY	1	1					
29	1	24311-000070	O-RING 1A P-7.0	1	1					
30	1	24311-000320	O-RING 1A P-32.0	1	1					

Remarks
 (1) OPTIONAL PART

Fig.3.FLYWHEEL HOUSING & OIL SUMP

(A)=4TNE98-SA (D)=
 (B)=4TNE98-G1A (E)=
 (C)= (F)=

3. FLYWHEEL HOUSING & OIL SUMP

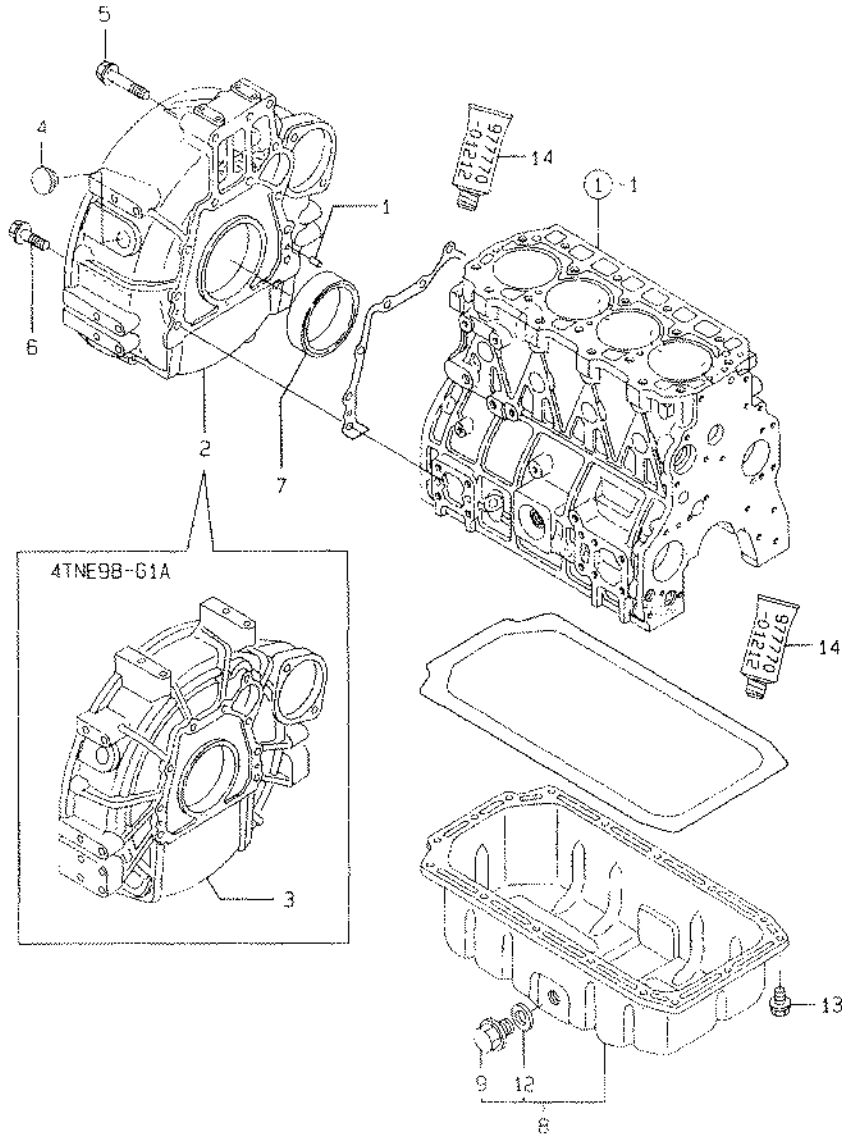

REF	LEV	PARTS NO	DESCRIPTION	Q'TY						R
				(A)	(B)	(C)	(D)	(E)	(F)	
1	1	129100-01580	PARALLEL PIN 8X16	2	2					
2	1	129955-01600	FLYWHEEL HOUSING	1						
3	1	129915-01600	FLYWHEEL HOUSING		1					
4	1	119620-01750	CAP. FLYWHEEL COVER	1	1					
5	1	26206-100702	BOLT M10X 70 PLATED	3						
6	1	26206-100352	BOLT M10X 35 PLATED	9	9					
7	1	124411-01780	SEAL HTC95,115,10	1	1					
8	1	129902-01710	SUMP ASSY. OIL	1	1					
9	2	119640-01640	DRAIN PLUG M22	1	1					
12	2	22190-220002	SEAL WASHER 22S	1	1					
13	1	26106-080122	BOLT M 8X 12 PLATED	21	21					
14	1	977770-01212	GASKET, LIQUID	1	1					

Remarks
 (1) OPTIONAL PART

Fig.4.CYLINDER HEAD & BONNET

4.CYLINDER HEAD & BONNET

(A)=4TNE98-SA (D)=
 (B)=4TNE98-G1A (E)=
 (C)= (F)=

4, CYLINDER HEAD & BONNET

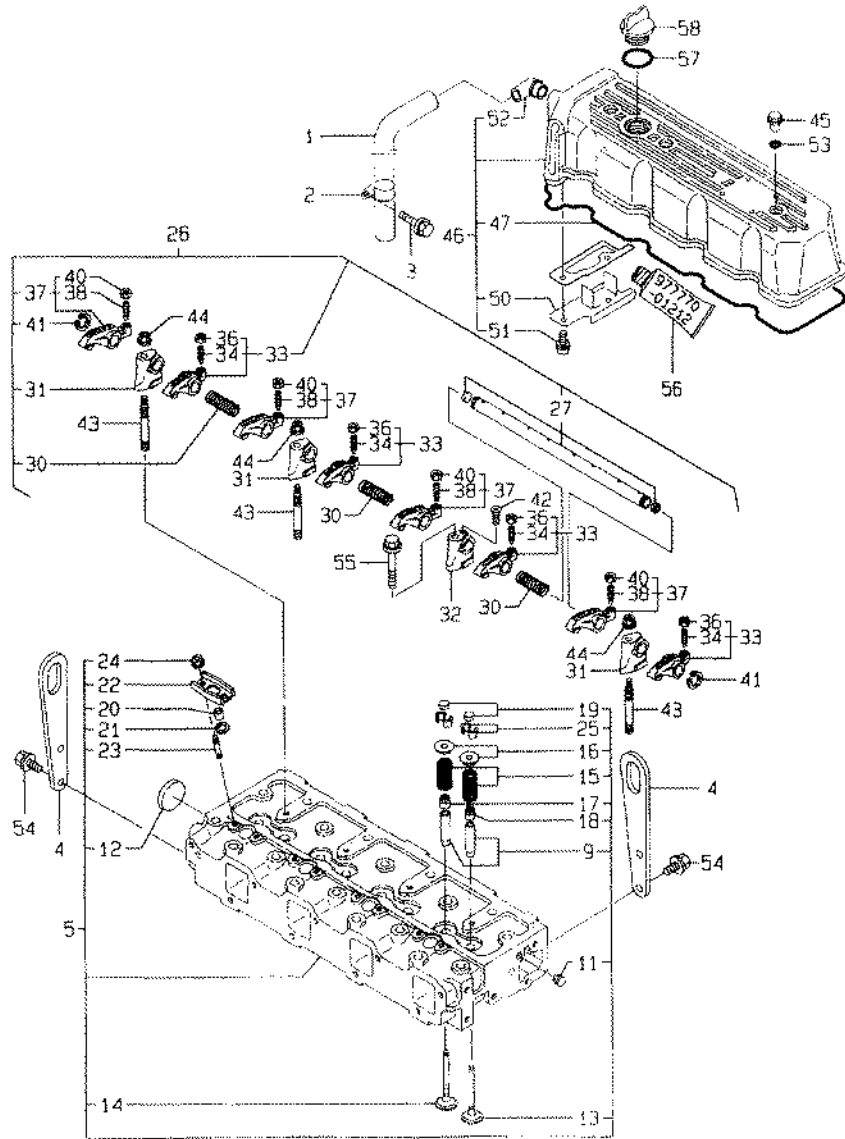

REF	LEV	PARTS NO	DESCRIPTION	QTY						I	R
				(A)	(B)	(C)	(D)	(E)	(F)		
1	1	119006-03090	HOSE, BREATHER	1	1						
2	1	129150-03100	RETAINER	1	1						
3	1	26106-080122	BOLT M 8X 12 PLATED	1	1						
4	1	129900-07900	LIFTER, ENGINE	2	2						
5	1	729900-11100	HEAD ASSY, CYLINDER	1	1						
9	2	129150-11810	GUIDE, VALVE	8	8						1
11	2	23871-005000	PLUG PT 1/16	1	1						
12	2	27241-400000	PLUG 40	1	1						
13	2	129900-11100	VALVE, SUCTION	4	4						
14	2	129900-11110	VALVE, EXHAUST	4	4						
15	2	129900-11120	SPRING, VALVE	8	8						
16	2	129795-11180	RETAINER, SPRING	8	8						
17	2	121400-11340	SEAL, VALVE STEM	4	4						
18	2	124460-11340	SEAL, VALVE STEM	4	4						
19	2	129150-11370	CAP, VALVE	8	8						
20	2	119625-11870	PROTECTOR, NOZZLE	4	4						
21	2	119625-11880	SEAT, NOZZLE	4	4						
22	2	119625-11900	RETAINER	4	4						
23	2	26216-060202	STUD M 6X 20 PLATED	8	8						
24	2	26366-060002	NUT M 6	8	8						
25	2	27310-080000	COTTER 8	16	16						
26	1	129900-11200	SUPPORT ASY,ROCK ARM	1	1						
27	2	129900-11240	SHAFT ASY,ROCK ARM	1	1						
30	2	129900-11280	SPRING	3	3						
31	2	129900-11510	SUPPORT	3	3						
32	2	129900-11520	SUPPORT	1	1						
33	2	129900-11650	ARM KIT, SUC. ROCKER	4	4						
34	3	129150-11230	SCREW, VALVE	4	4						
36	3	129150-11750	NUT M8XP1.0	4	4						
37	2	129900-11660	ARM KIT, EXH. ROCKER	4	4						
38	3	129150-11230	SCREW, VALVE	4	4						
40	3	129150-11750	NUT M8XP1.0	4	4						
41	2	22242-000180	CIRCLIP 18	2	2						
42	2	26577-040122	SCREW M 4 X 12	1	1						
43	1	129900-11530	STUD BOLT	3	3						
44	1	26366-100002	NUT M10	3	3						
45	1	124160-11360	KNOB	3	3						
46	1	129900-11350	BONNET ASSY	1	1						
47	2	129900-11310	GASKET, BONNET	1	1						
50	2	129900-11600	PLATE	1	1						
51	2	26022-050122	SCREW M 5X 12	2	2						
52	2	119100-11330	JOINT, BREATHER	1	1						
53	1	24311-000120	O-RING 1A P 12.0	3	3						
54	1	26106-080162	BOLT M 8X 16 PLATED	4	4						
55	1	26106-100652	BOLT M10X 65 PLATED	1	1						
56	1	977770-01212	GASKET, LIQUID	1	1						2
57	1	24311-000320	O-RING 1A P 32.0	1	1						
58	1	124160-01751	CAP, LUB OIL SUPPLY	1	1						

Remarks
 (1) REPAIR PART
 (2) OPTIONAL PART

Fig.5.SUCTION MANIFOLD

(A):4TNE66-SA (D):
 (B):4TNE68-G1A (E):
 (C): (F):

5, SUCTION MANIFOLD

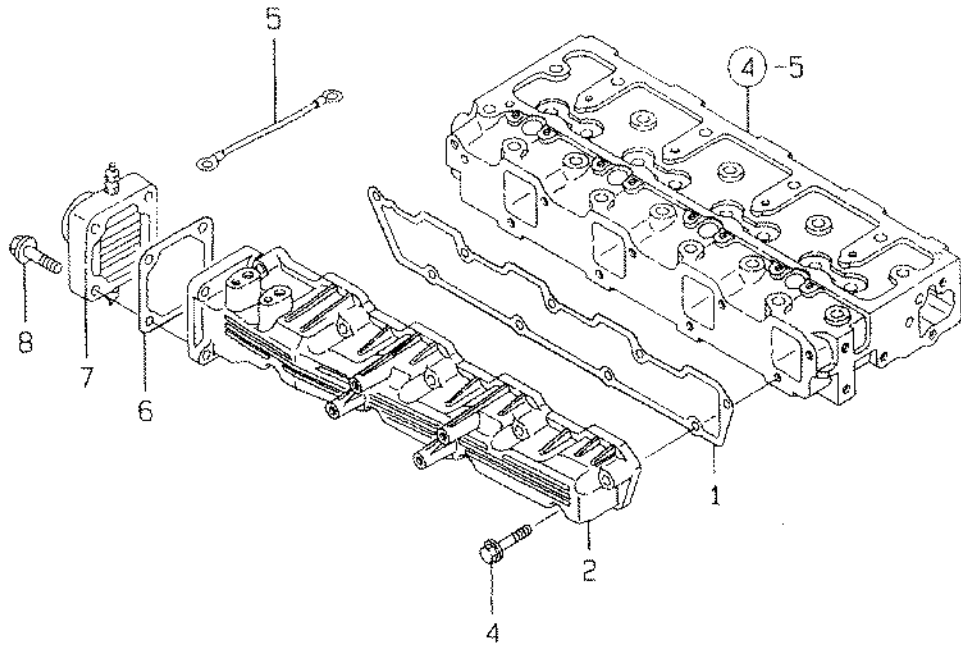

REF	LEV	PARTS NO	DESCRIPTION	QTY					
				(A)	(B)	(C)	(D)	(E)	(F)
1	1	129900-12050	GASKET, SUC MANIFOLD	1	1				
2	1	129900-12000	MANIFOLD,INT	1	1				
4	1	26106-080452	BOLT M 8X 45 PLATED	9	9				
5	1	129100-77820	CORD, EARTH	1	1				
6	1	121850-77021	GASKET, (NON-ASB)	1	1				
7	1	121850-77050	HEATER, AIR	1	1				
8	1	26106-080352	BOLT M 8X 35 PLATED	4	4				

Fig.6 EXHAUST MANIFOLD

(A)=FINESS-SA (D)=
 (B)=4TNESS-G1A (E)=
 (C)= (F)=

6, EXHAUST MANIFOLD

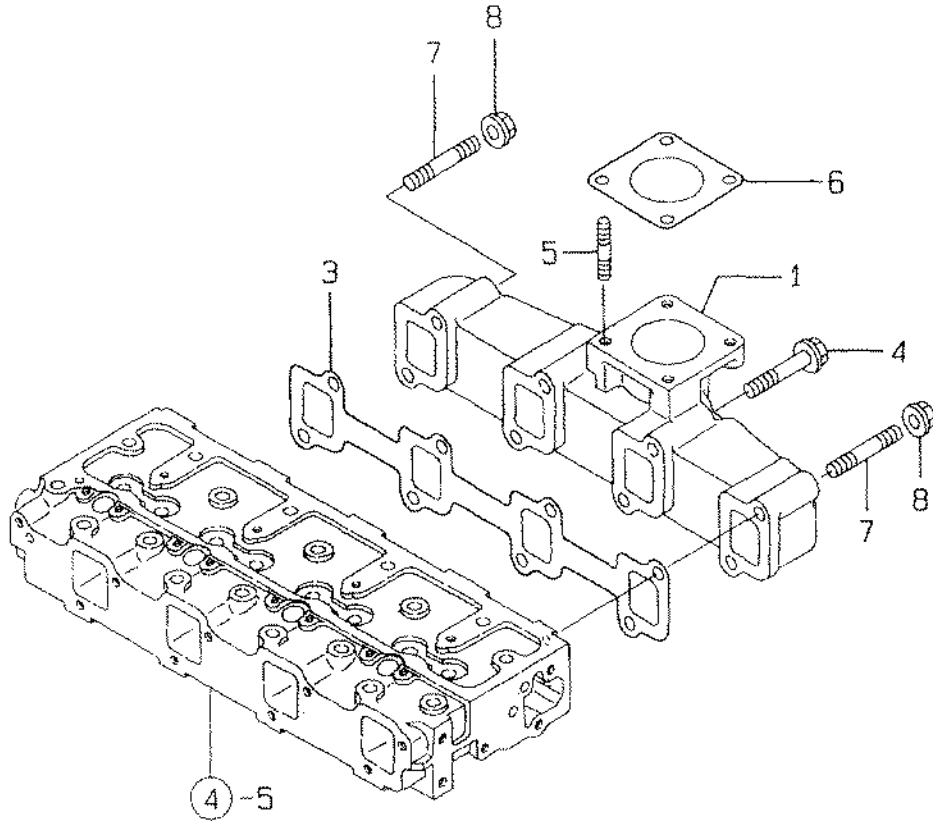

REF	LEV	PARTS NO	DESCRIPTION	QTY					
				(A)	(B)	(C)	(D)	(E)	(F)
1	1	129900-13200	MANIFOLD, EXHAUST	1	1				
3	1	129900-13251	GASKET	1	1				
4	1	26106-080802	BOLT M 8X 80 PLATED	6	6				
5	1	26216-080222	STUD M 8X 22 PLATED	4	4				
6	1	129400-13201	GASKET, (NON-ASB)	1	1				
7	1	26216-080802	STUD M 8X 80 PLATED	2	2				
8	1	26366-080002	NUT M 8	2	2				

Fig.7.CAMSHAFT & DRIVING GEAR

7.CAMSHAFT & DRIVING GEAR

(A)=4TNE98-SA (D)=
 (B)=4TNE98-G1A (E)=
 (C)= (F)=

7. CAMSHAFT & DRIVING GEAR

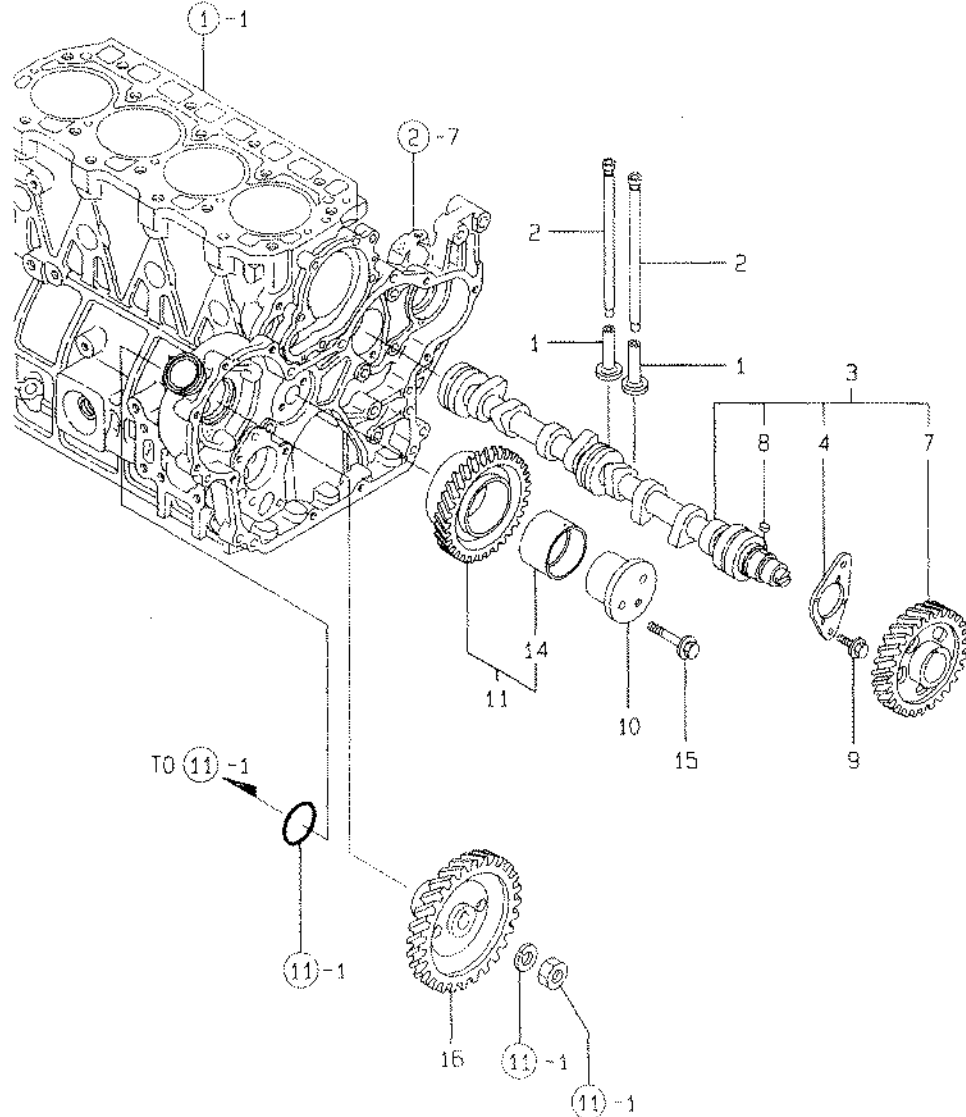

REF	LEV	PARTS NO	DESCRIPTION	QTY					
				(A)	(B)	(C)	(D)	(E)	(F)
1	1	129150-14200	TAPPET	8	8				
2	1	129900-14400	ROD. PUSH	8	8				
3	1	129900-14580	CAMSHAFT ASSY	1	1				
4	2	129150-02450	METAL THRUST	1	1				
7	2	129900-14100	GEAR. CAMSHAFT	1	1				
8	2	22512-070140	KEY 7X 14	1	1				
9	1	26106-080162	BOLT M 8X 16 PLATED	2	2				
10	1	129900-25060	SHAFT. IDLER	1	1				
11	1	129900-25100	GEAR ASSY. IDLE	1	1				
14	2	129150-25920	BUSH. IDLE GEAR	1	1				
15	1	26106-080552	BOLT M 8X 55 PLATED	2	2				
16	1	129900-25900	GEAR. FL-P	1	1				

Remarks
 (1) REPAIR PART

Fig.8.CRANKSHAFT & PISTON

(A)=4TNE98-SA (D)=
 (B)=4TNE98-G1A (E)=
 (C)= (F)=

8. CRANKSHAFT & PISTON

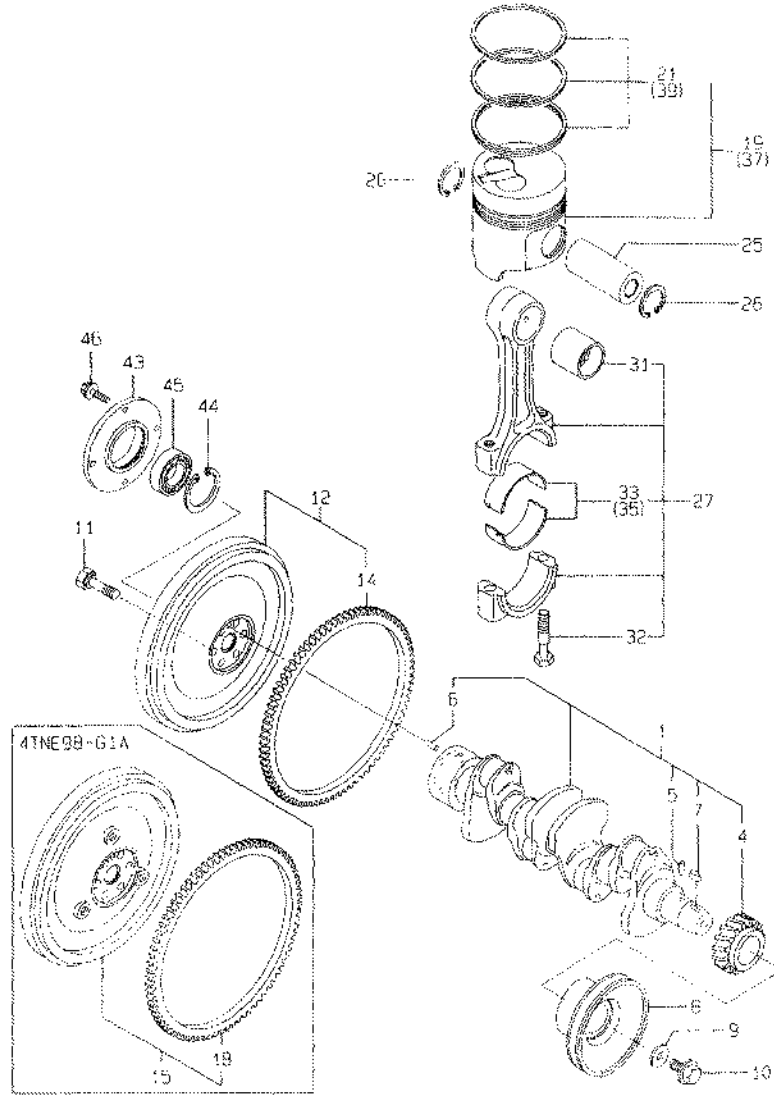

REF	LEV	PARTS NO	DESCRIPTION	Q'TY						R	
				(A)	(B)	(C)	(D)	(E)	(F)		
1	1	129902-21000	CRANKSHAFT COMP	1							
4	2	129900-21200	GEAR, CRANKSHAFT	1							
5	2	121850-21290	PARALLEL PIN	1							
6	2	121850-21920	PARALLEL PIN 10X22	1							
7	2	22512-070140	KEY 7X 14	1							
8	1	129900-21670	V-PULLEY	1							
9	1	129900-21640	WASHER	1							
10	1	121850-21680	BOLT, V-PULLEY	1							
11	1	121850-21130	BOLT, FLYWHEEL	6							
12	1	129955-21590	FLYWHEEL ASSY	1							
14	2	129900-21600	GEAR, RING	1							
15	1	129902-21580	FLYWHEEL ASSY								
18	2	127410-21480	RING GEAR								
19	1	129902-22080	PISTON W/RING	4							
21	2	129903-22050	RING SET	4							
25	1	120130-22301	PIN, PISTON	4							
26	1	22252-000300	CIRCLIP 30	8							
27	1	129900-23000	ROD ASSY, CONNECTING	4							
31	2	129900-23910	BUSH, PISTON PIN	4							1
32	2	129900-23200	BOLT, ROD	8							
33	2	129900-23600	METAL ASSY, CRANKPIN	4							
35	1	129900-23610	BEARING, PIN U.S.=0 25	4							2
37	1	129902-22900	PISTON W/RING O.S.=25	4							3
39	2	129903-22950	RING SET O.S.=0 25	4							3
43	1	171085-21451	HOUSING, BEARING	1							
44	1	22252-000721	RING 72	1							
45	1	24105-063064	BALL BEARING	1							
46	1	26106-080222	BOLT M 8X 22 PLATED	4							

Remarks

- (1) REPAIR PART
- (2) UNDER-SIZE (U.S.=0 25) PART
- (3) OVER-SIZE (O.S.=0 25) PART

Fig.9.LUB.OIL SYSTEM

9, LUB.OIL SYSTEM

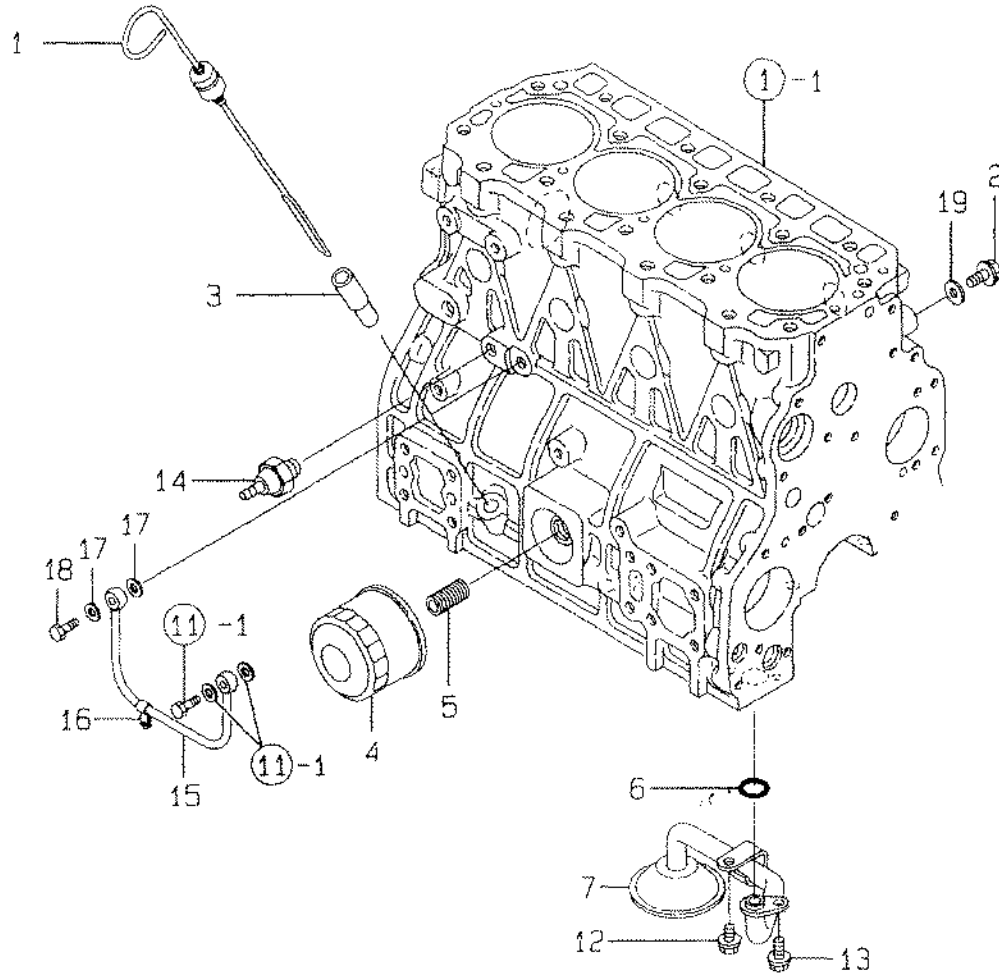

9.LUB.OIL SYSTEM

(A)=4TNE88-SA (D)=
 (B)=4TNE88-G1A (E)=
 (C)= (F)=

REF	LEV	PARTS NO	DESCRIPTION	QTY						R
				(A)	(B)	(C)	(D)	(E)	(F)	
1	1	129900-34800	DIPSTICK	1	1					
2	1	26106-080122	BOLT M 8X 12 PLATED	1	1					
3	1	121520-34810	GUIDE, DIPSTICK	1	1					
4	1	129150-35151	FILTER 80X80L	1	1					
5	1	119000-35140	STUD, LUB OIL FILTER	1	1					
6	1	129900-32030	O-RING P20	1	1					
7	1	129900-35000	PIPE ASSY, LUB OIL	1	1					
12	1	26106-080122	BOLT M 8X 12 PLATED	1	1					
13	1	26106-080162	BOLT M 8X 16 PLATED	1	1					
14	1	124160-39450	SWITCH, OIL PRESSURE	1	1					
15	1	129900-39350	PIPE, LUB OIL	1	1					
16	1	23297-060081	RETAINER 6X 8	1	1					
17	1	23414-080000	GASKET 8, ROUND	2	2					
18	1	23857-030000	JOINT BOLT 3	1	1					
19	1	22190-080002	SEAL WASHER 8S	1	1					

Fig.10.COOLING WATER SYSTEM

(A)=4TNE98-SA (D)=
(B)=4TNE98-G1A (E)=
(C)= (F)=

10. COOLING WATER SYSTEM

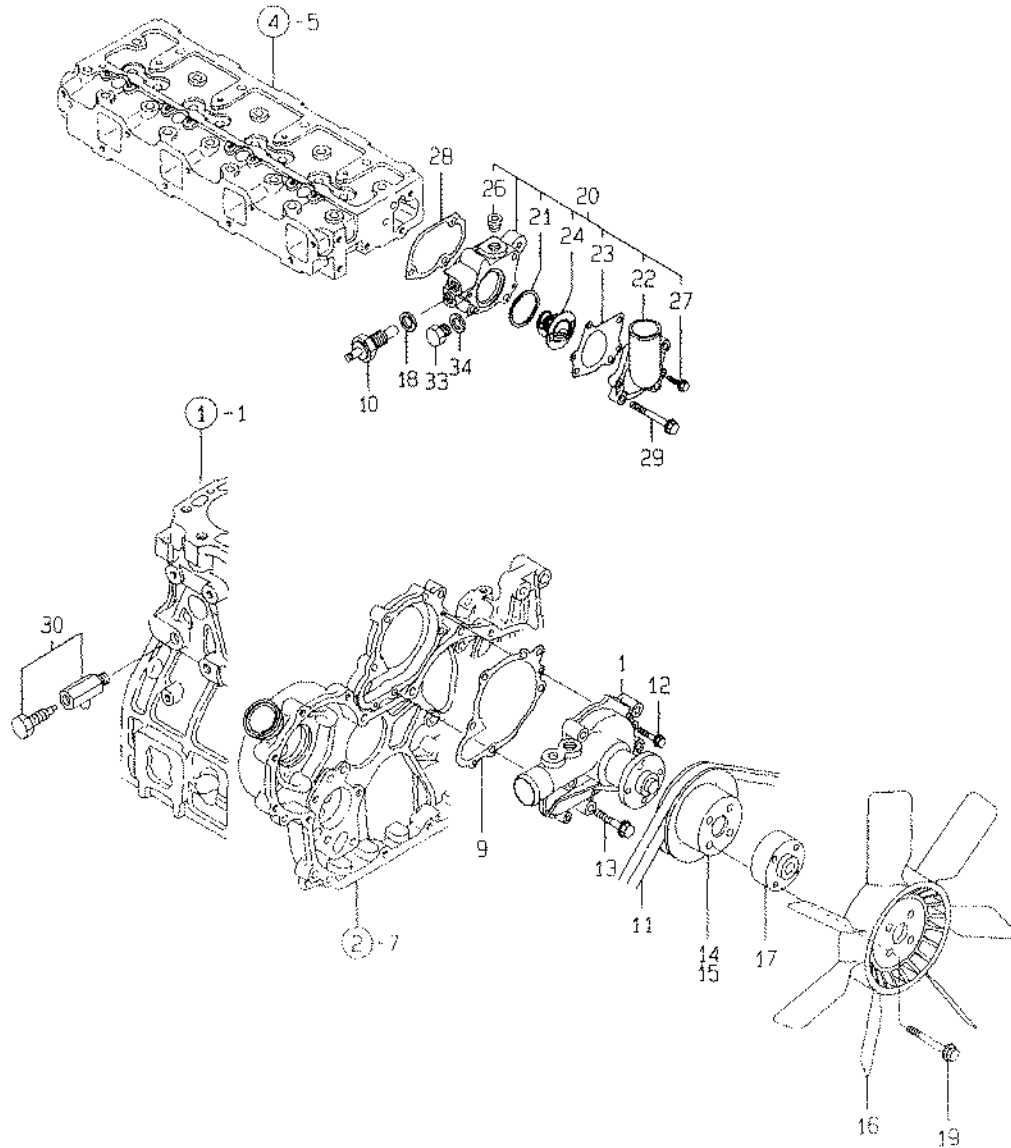

REF	LEV	PARTS NO	DESCRIPTION	QTY						R
				(A)	(B)	(C)	(D)	(E)	(F)	
1	1	129900-42000	PUMP, COOLING WATER	1	1					
9	1	129900-42020	GASKET, CW-P	1	1					
10	1	121250-44901	SWITCH, THERMO(110C	1	1					
11	1	25132-004100	V-BELT	1	1					
12	1	26106-060302	BOLT M 6X 30 PLATED	2	2					
13	1	26106-080552	BOLT M 8X 55 PLATED	5	5					
14	1	129900-42450	PULLEY	1						
15	1	129900-42461	PULLEY		1					
16	1	129900-44700	FAN	1	1					
17	1	119005-44761	SPACER	1	1					
18	1	124465-44950	GASKET 16	1	1					
19	1	26014-080502	BOLT M 8X 50	4	4					
20	1	129951-49800	THERMOSTAT CASE ASSY	1	1					
21	2	121850-49550	GASKET, THERMOSTAT	1	1					
22	2	129900-49530	COVER	1	1					
23	2	129900-49540	GASKET, THERMOSTAT	1	1					
24	2	121850-49810	THERMOSTAT	1	1					
26	2	23871-030000	PLUG PT3/8,SCREW	1	1					
27	2	26106-060252	BOLT M 6X 25 PLATED	2	2					
28	1	129900-49830	GASKET, CASE	1	1					
29	1	26106-080702	BOLT M 8X 70 PLATED	3	3					
30	1	119620-49290	COCK ASSY 1/4	1	1					
33	1	121450-42450	PLUG M16	1	1					
34	1	124465-44950	GASKET 16	1	1					

Fig.11.FUEL INJECTION PUMP

11.FUEL INJECTION PUMP

(A)=4TNE98-SA (D)=
 (B)=4TNE98-G1A (E)=
 (C)= (F)=

11. FUEL INJECTION PUMP

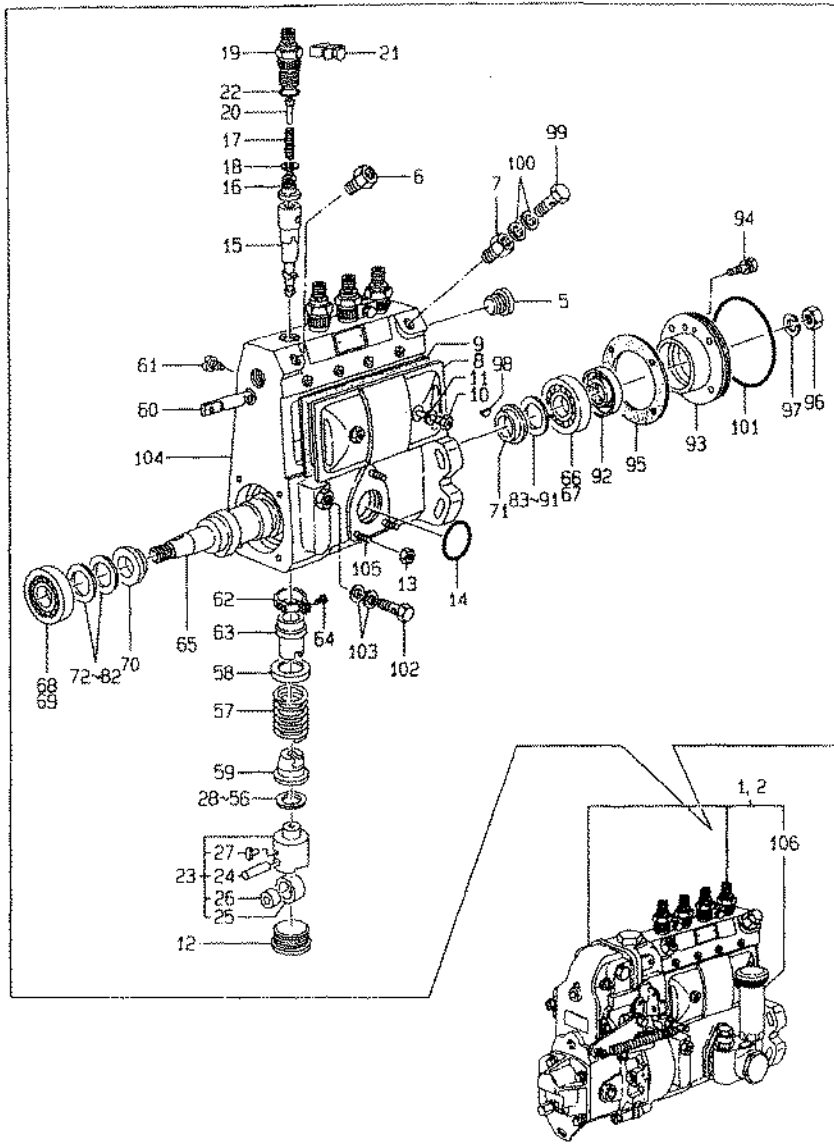

Remarks
 (1) GOVERNOR (FIG NO 18) & FEED PUMP
 (FIG NO 19) IS INCORPORATED IN
 THIS FUEL INJECTION PUMP
 (REF NO 1.2)

REF	LEV	PARTS NO	DESCRIPTION	QTY					
				(A)	(B)	(C)	(D)	(E)	(F)
1	1	129955-51010	FUEL INJECTION PUMP	1					1
2	1	129955-51000	FUEL INJECTION PUMP						1
5	2	X1340260000	PLUG	1	1				
6	2	X1310022000	CAP	1	1				
7	2	X1310022000	CAP	1	1				
8	2	X1310286220	COVER	1	1				
9	2	X1310111900	GASKET	1	1				
10	2	X1310171000	SCREW	2	2				
11	2	X0293406020	GASKET	2	2				
12	2	X1310341401	PLUG	4	4				
13	2	X1392060400	NUT	3	3				
14	2	X0296331010	O-RING	1	1				
15	2	X1311523420	PLUNGER	4	4				
16	2	X1311607920	DELIVERY VALVE	4	4				
17	2	X1311123500	SPRING	4	4				
18	2	X1311151600	GASKET	4	4				
19	2	X1311167600	HOLDER	4	4				
20	2	X1311172300	STOPPER	4	4				
21	2	X1311220520	PLATE	2	2				
22	2	X0296320030	O-RING	4	4				
23	2	X1312000220	TAPPET	4	4				
24	3	X1312030200	PIN	4	4				
25	3	X1312041000	ROLLER	4	4				
26	3	X1312050500	BUSH	4	4				
27	3	X1312060200	GUIDE	4	4				
28	2	X0293110020	SHIM	1	1				
29	2	X0293110030	SHIM	1	1				
30	2	X0293110040	SHIM	1	1				
31	2	X0293110050	SHIM	1	1				
32	2	X0293110060	SHIM	1	1				
33	2	X0293110070	SHIM	1	1				
34	2	X0293110080	SHIM	1	1				
35	2	X0293110090	SHIM	1	1				
36	2	X0293110110	SHIM	1	1				
37	2	X0293110120	SHIM	1	1				
38	2	X0293110130	SHIM	1	1				
39	2	X0293110140	SHIM	1	1				
40	2	X0293110270	SHIM	1	1				
41	2	X0293110280	SHIM	1	1				
42	2	X0293110290	SHIM	1	1				
43	2	X0293110310	SHIM	1	1				
44	2	X0293110320	SHIM	1	1				
45	2	X0293110330	SHIM	1	1				
46	2	X0293110340	SHIM	1	1				
47	2	X0293110350	SHIM	1	1				
48	2	X0293110490	SHIM	1	1				
49	2	X0293110500	SHIM	1	1				
50	2	X0293110580	SHIM	1	1				
51	2	X0293110590	SHIM	1	1				
52	2	X0293110600	SHIM	1	1				
53	2	X0293110610	SHIM	1	1				
54	2	X0293110620	SHIM	1	1				
55	2	X0293110630	SHIM	1	1				
56	2	X0293110710	SHIM	1	1				

++ CONTINUE ++

Fig.11.FUEL INJECTION PUMP

11.FUEL INJECTION PUMP

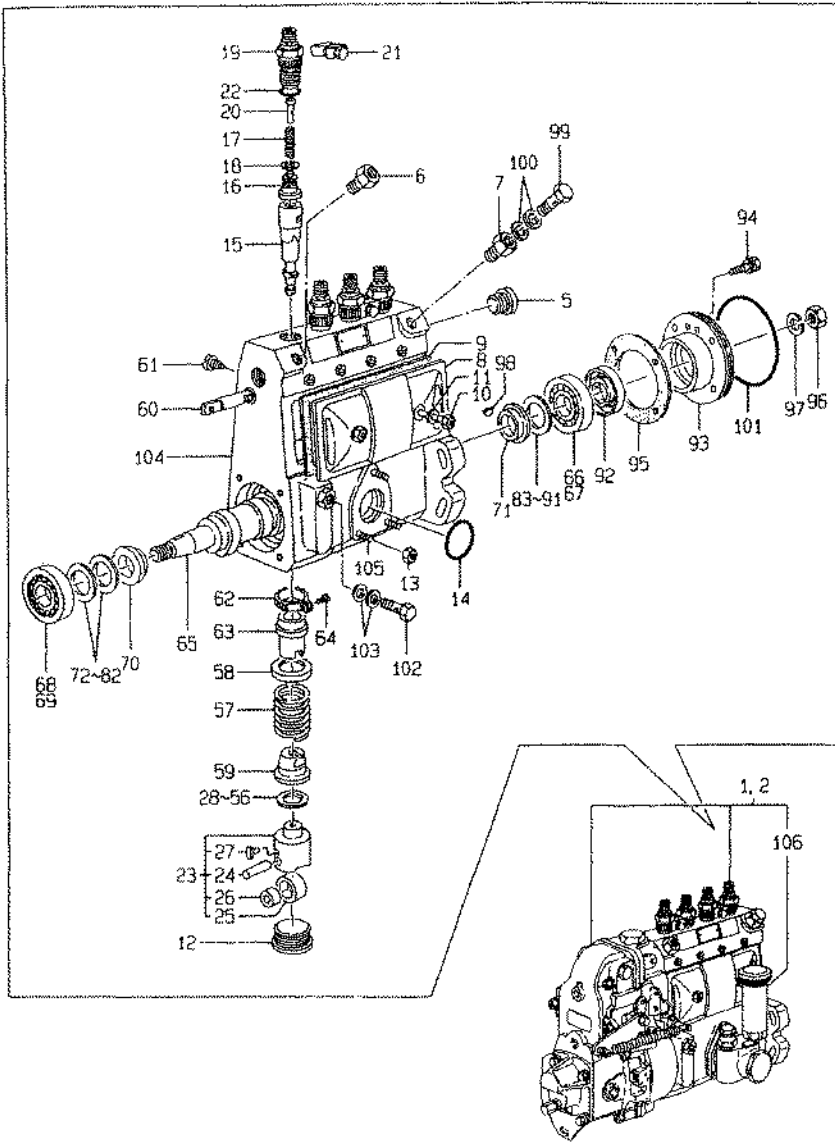

Remarks
 (1) GOVERNOR (FIG. NO. 18) & FEED PUMP
 (FIG. NO. 19) IS INCORPORATED IN
 THIS FUEL INJECTION PUMP
 (REF. NO. 1, 2)

11.FUEL INJECTION PUMP

(A)=4 TNE98-SA (D)=
 (B)=4 TNE98-G1A (E)=
 (C)= (F)=

REF	LEV	PARTS NO	DESCRIPTION	QTY						I	R
				(A)	(B)	(C)	(D)	(E)	(F)		
57	2	X1312152500	SPRING	4	4						
58	2	X1312160100	SEAT, SPRING	4	4						
59	2	X1312170200	SEAT, SPRING	4	4						
60	2	X1312540600	RACK, CONTROL	1	1						
61	2	X1312260300	SCREW	1	1						
62	2	X1312400100	PINION	4	4						
63	2	X1312410100	SLEEVE, CONTROL	4	4						
64	2	X1312420100	SCREW	4	4						
65	2	X1313612700	CAMSHAFT	1	1						
66	2	X0166402030	BEARING	1	1						
67	2	X0282020020	BEARING	1	1						
68	2	X0166302030	BEARING	1	1						
69	2	X0292017020	BEARING	1	1						
70	2	X1313020300	RING	1	1						
71	2	X1313021000	RING	1	1						
72	2	X0293117010	SHIM	1	1						
73	2	X0293117020	SHIM	1	1						
74	2	X0293117030	SHIM	1	1						
75	2	X0293117040	SHIM	1	1						
76	2	X0293117050	SHIM	1	1						
77	2	X0293117060	SHIM	1	1						
78	2	X0293117070	SHIM	1	1						
79	2	X0293117090	SHIM	1	1						
80	2	X0293117210	SHIM	1	1						
81	2	X0293117220	SHIM	1	1						
82	2	X1394170000	SHIM	1	1						
83	2	X0293120220	SHIM	1	1						
84	2	X0293120230	SHIM	1	1						
85	2	X0293120240	SHIM	1	1						
86	2	X0293120250	SHIM	1	1						
87	2	X0293120260	SHIM	1	1						
88	2	X0293120270	SHIM	1	1						
89	2	X0293120290	SHIM	1	1						
90	2	X0293120300	SHIM	1	1						
91	2	X1394200400	SHIM	1	1						
92	2	X0296220190	SEAL, OIL	1	1						
93	2	X1313301800	COVER	1	1						
94	2	X0200062040	BOLT	4	4						
95	2	X1313211900	GASKET	1	1						
96	2	X0131214140	NUT	1	1						
97	2	X0293214010	SPRING WASHER	1	1						
98	2	X0294704030	WOODRUFF KEY	1	1						
99	2	X0297314680	EYE BOLT	1	1						
100	2	X0265141840	GASKET	2	2						
101	2	X0296375020	O-RING	1	1						
102	2	X0297310120	EYE BOLT	1	1						
103	2	X0265101340	GASKET	2	2						
104	2	X1310641621	FLANGED HOUSING	1	1						
105	2	X0290406020	STUD	3	3						
106	2	129900-52010	PUMP ASSY.FUEL FEED	1	1						

Fig.12.FUEL INJECTION VALVE

12. FUEL INJECTION VALVE

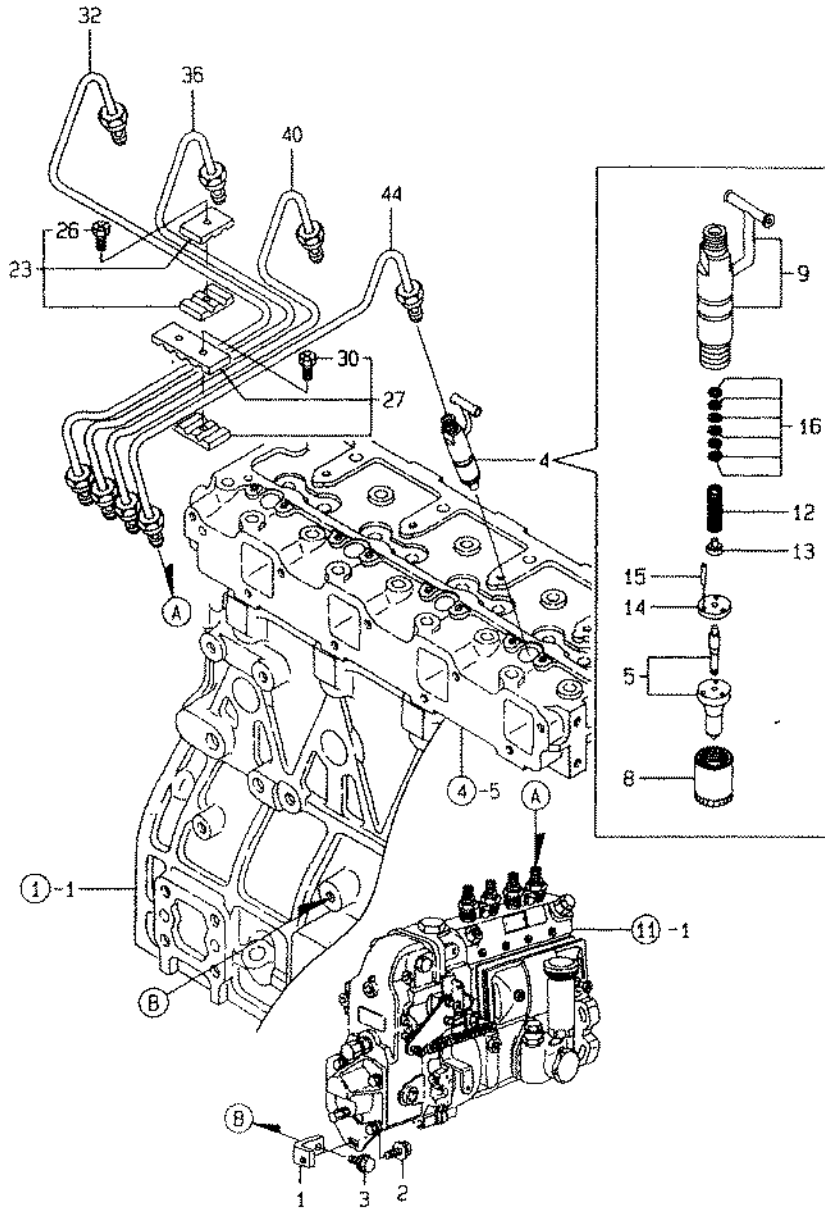

Y00R4580 12.FUEL INJECTION VALVE

(A)=4TNE98-SA (D)=
 (B)=4TNE98-G1A (E)=
 (C)= (F)=

REF	LEV	PARTS NO	DESCRIPTION	QTY						
				(A)	(B)	(C)	(D)	(E)	(F)	
1	1	129900-01950	BRACKET	1	1					
2	1	26106-100142	BOLT M10X 14 PLATED	1	1					
3	1	26106-080202	BOLT M 8X 20 PLATED	1	1					
4A	1	729902-53200	VALVE, FUEL	4						
4B	1	729982-53100	VALVE ASSY, F INJECT		4					
5A	2	129902-53050	NOZZLE	4						
5B	2	129982-53000	NOZZLE		4					
8	2	114250-53080	NUT, NOZZLE CASE	4	4					
9	2	129100-53100	HOLDER ASSY, NOZZLE	4	4					
12	2	114250-53120	SPRING, NOZZLE	4	4					
13	2	114250-53130	SEAT, NOZZLE SPRING	4	4					
14	2	114250-53140	PLATE, STOP	4	4					
15	2	114250-53210	PIN	8	8					
16	2	114250-53400	SHIM PACK	4	4					
23	1	119305-59120	RETAINER	2	2					
26	2	129150-59131	BOLT M4X14,HEX.SCKT.	2	2					
27	1	129550-59120	RETAINER	1	1					
30	2	129150-59131	BOLT M4X14,HEX.SCKT.	2	2					
32	1	129902-59810	PIPE NO.1, F.INJECT.	1	1					
36	1	129902-59820	PIPE NO.2, F.INJECT.	1	1					
40	1	129902-59830	PIPE NO.3, F.INJECT.	1	1					
44	1	129902-59840	PIPE NO.4, F.INJECT.	1	1					

Fig.13.FUEL LINE

13, FUEL LINE

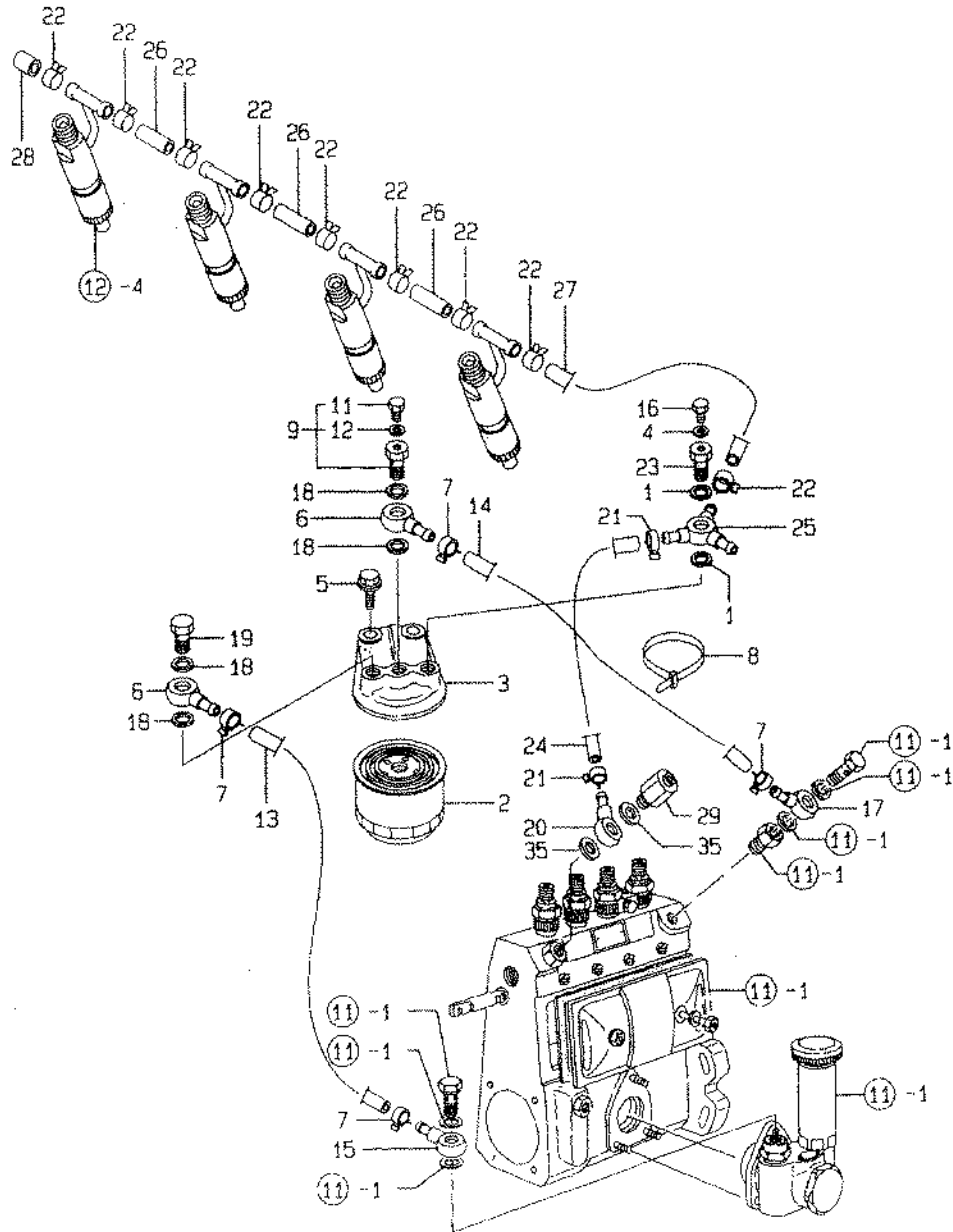

(A)=4TNE98-SA (D)=
 (B)=4TNE98-G1A (E)=
 (C)= (F)=

REF	LEV.	PARTS NO	DESCRIPTION	QTY						R
				(A)	(B)	(C)	(D)	(E)	(F)	
1	1	22190-140002	SEAL WASHER 14S		2	2				
2	1	119000-55600	FILTER, FUEL	1	1					
3	1	129470-55610	BODY, FUEL FILTER	1	1					
4	1	23414-080000	GASKET 8, ROUND	1	1					
5	1	26106-100252	BOLT M10X 25 PLATED	2	2					
6	1	101304-59020	JOINT 12, PIPE	2	2					
7	1	124766-59050	CLAMP 12	4	4					
8	1	121855-59111	CLAMP, PIPE	2	2					
9	1	103854-59191	BOLT W/PLUG & SEAL	1	1					
11	2	124060-59380	PLUG	1	1					
12	2	22190-060002	SEAL WASHER 6S	1	1					
13	1	129900-59510	PIPE, FUEL	1	1					
14	1	129900-59510	PIPE, FUEL	1	1					
15	1	119006-59910	PIPE, JOINT	1	1					
16	1	26106-080102	BOLT M 8X 10 PLATED	1	1					
17	1	121855-59880	JOINT	1	1					
18	1	22190-120002	SEAL WASHER 12	4	4					
19	1	23857-060000	JOINT BOLT 6	1	1					
20	1	121855-59880	JOINT	1	1					
21	1	124766-59050	CLAMP 12	2	2					
22	1	124066-59100	CLAMP 8	9	9					
23	1	129495-59300	BOLT, PIPE JOINT	1	1					
24	1	105025-59580	PIPE, FUEL OIL	1	1					
25	1	129470-59530	JOINT, FUEL RETN PIPE	1	1					
26	1	121250-59550	PIPE, FUEL	3	3					
27	1	124950-59560	PIPE, FUEL RETURN	1	1					
28	1	129150-59580	CAP	1	1					
29	1	128300-59910	VALVE ASSY, OVER-FLOW	1	1					
35	1	22190-140002	SEAL WASHER 14S	2	2					

Fig.14.ENGINE STOP DEVICE

(A)=4TNE98-SA (D)=
 (B)=4TNE98-G1A (E)=
 (C)= (F)=

14, ENGINE STOP DEVICE

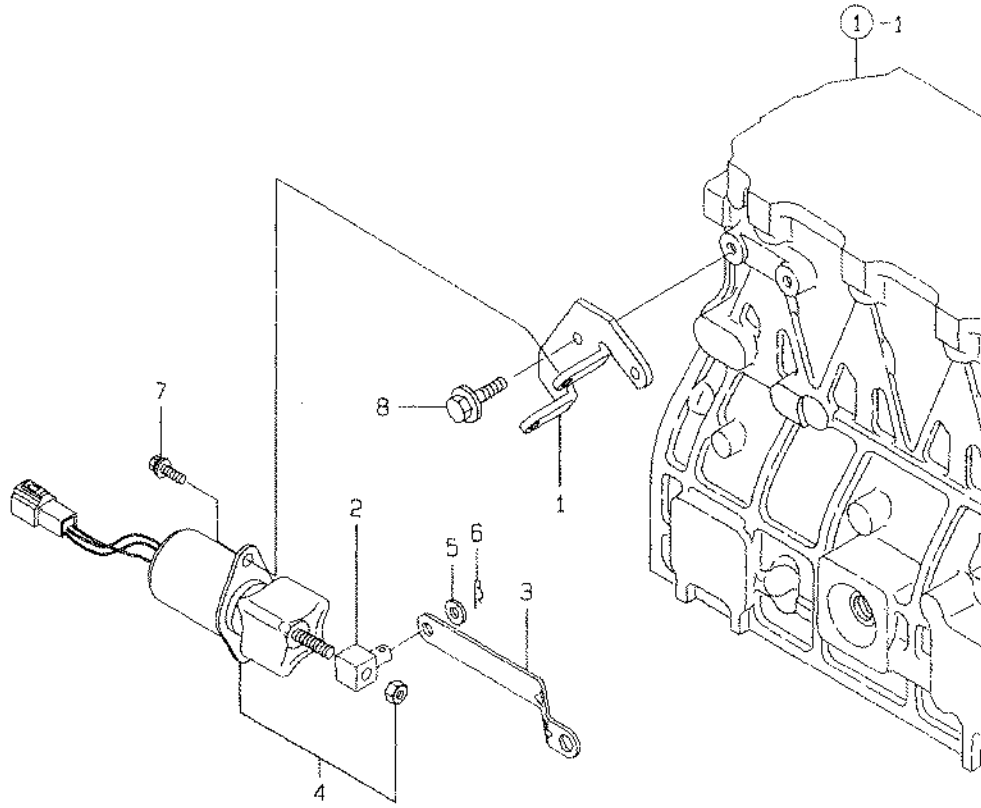

REF	LEV	PARTS NO	DESCRIPTION	QTY						
				(A)	(B)	(C)	(D)	(E)	(F)	
1	1	129915-66810	BRACKET.SOLENOID	1	1					
2	1	119620-66820	JOINT	1	1					
3	1	129915-66820	LINK.SOLENOID	1	1					
4	1	119807-77800	SOLENOID.STOP	1	1					
5	1	22117-060000	WASHER 6	2	2					
6	1	22360-060000	SNAP PIN 6	2	2					
7	1	26106-080102	BOLT M 6X 10 PLATED	2	2					
8	1	26106-080162	BOLT M 8X 16 PLATED	2	2					

Fig.15.STARTING MOTOR

(A)=4TNE98-SA (D)=
 (B)=4TNE98-G1A (E)=
 (C)= (F)=

15. STARTING MOTOR

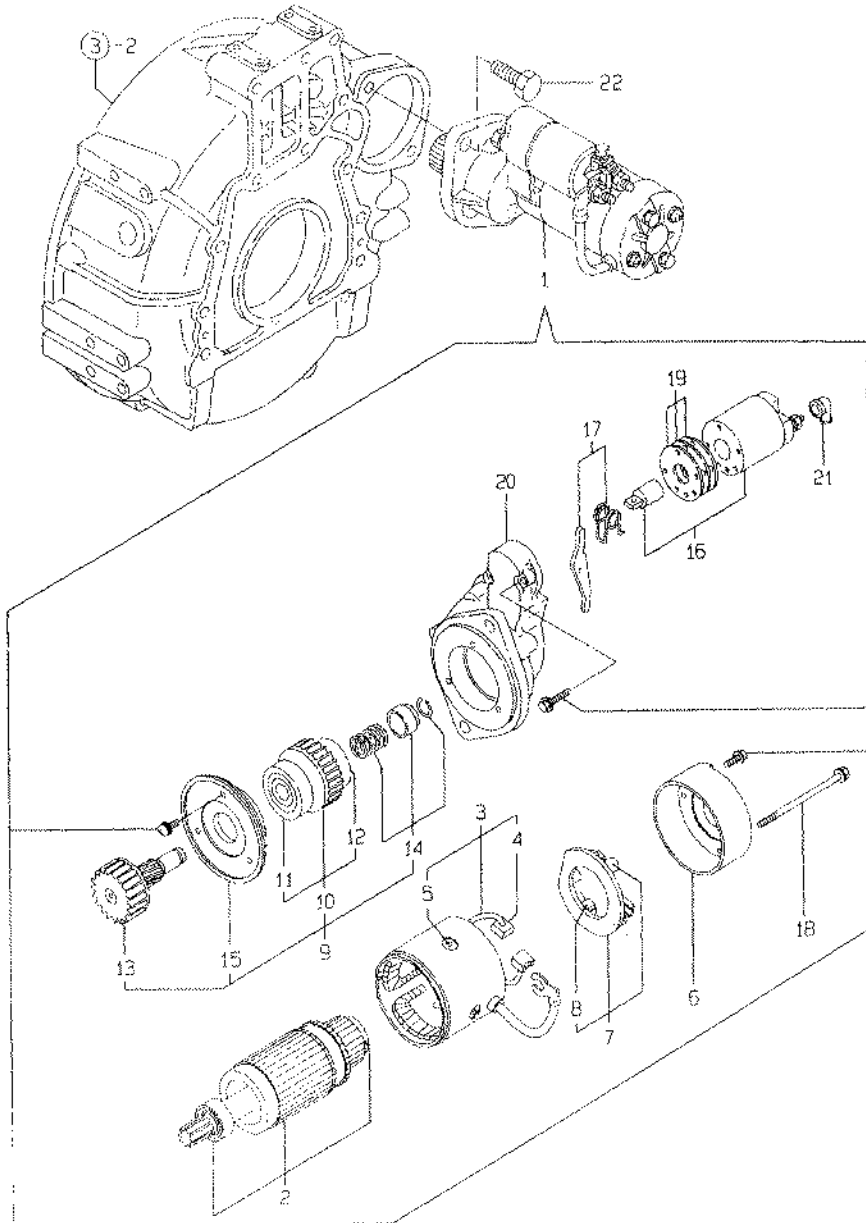

REF	LEV	PARTS NO	DESCRIPTION	QTY						
				(A)	(B)	(C)	(D)	(E)	(F)	
1	1	129900-77010	STARTER(2.3KW	1	1					
2	2	129900-77400	ARMATURE ASSY	1	1					
3	2	129900-77440	COIL ASSY. FIELD	1	1					
4	3	129900-77450	BRUSH (+)	2	2					
5	3	171008-77450	SCREW. POLE CORE SET	4	4					
6	2	129900-77460	COVER, REAR	1	1					
7	2	129900-77480	HOLDER ASSY. BRASH	1	1					
8	3	129900-77500	BRASH (-)	2	2					
9	2	129900-77510	PINION ASSY	1	1					
10	3	129900-77520	CLUTCH ASSY	1	1					
11	4	171008-77730	BALL BEARING (3)	1	1					
12	4	171008-77740	BALL BEARING (4)	1	1					
13	3	129900-77540	SHAFT, PINION	1	1					
14	3	129900-77550	STOPPER SET	1	1					
15	3	129900-77610	RETAINER, BEARING	1	1					
16	2	129900-77590	SWITCH ASSY. MAGNETIC	1	1					
17	2	129900-77620	SHIFT LEVER SET	1	1					
18	2	129900-77640	BOLT, THROUGH	2	2					
19	2	129900-77650	COVER ASSY. DUST	1	1					
20	2	129900-77710	HOUSING, GEARS	1	1					
21	2	171008-77750	COVER, M TERMINAL	1	1					
22	1	26116-120302	BOLT M12X 30 PLATED	2	2					

Fig.16.GENERATOR

(A)=4TNE98-SA (D)=
 (B)=4TNE98-G1A (E)=
 (C)= (F)=

16. GENERATOR

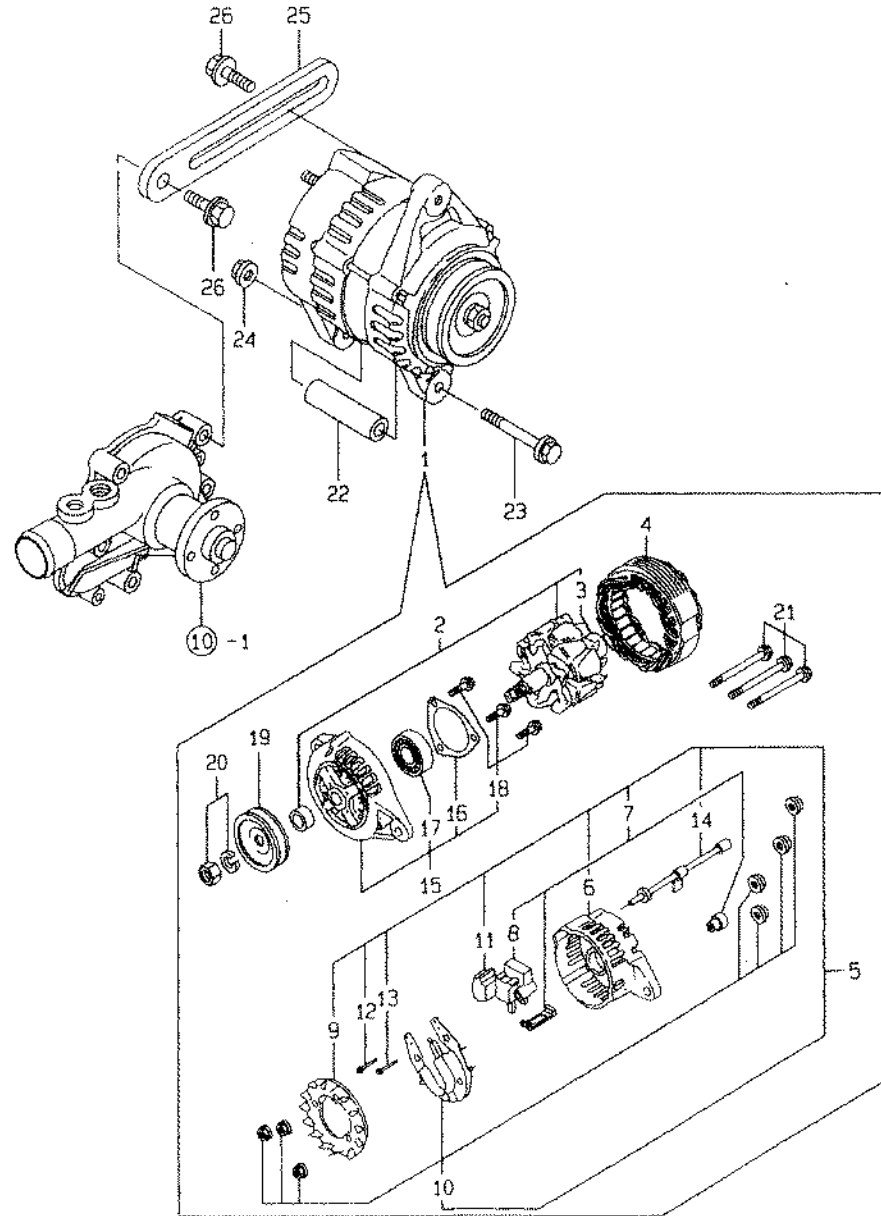

REF.	LEV	PARTS NO	DESCRIPTION	QTY						I	R
				(A)	(B)	(C)	(D)	(E)	(F)		
1	1	119836-77200	GENERATOR	1	1						
2	2	119836-77700	ROTOR ASSY	1	1						
3	3	119836-77850	BALL BEARING	1	1						
4	2	119836-77710	STARTER ASSY	1	1						
5	2	119836-77721	COVER ASSY. REAR	1	1						
6	3	119836-77730	COVER. REAR	1	1						
7	3	119836-77741	BRUSH ASSY.REGULATOR	1	1						
8	4	119836-77750	BRUSH ASSY	1	1						
9	3	119836-77760	GUIDE. FAN SIDE	1	1						
10	3	119836-77770	DIODE ASSY	1	1						
11	3	119836-77780	CONDENSER	1	1						
12	3	119836-77871	BOLT (1)	1	1						
13	3	119836-77880	BOLT (2)	1	1						
14	3	119836-77890	WIRE ASSY. LEAD	1	1						
15	2	119836-77790	COVER ASSY. FRONT	1	1						
16	3	119836-77800	RETAINER. BEARING	1	1						
17	3	119836-77840	BALL BEARING	1	1						
18	3	119836-77860	SCREW KID	1	1						
19	2	119836-77810	PULLEY	1	1						
20	2	119836-77820	NUT ASSY. PULLEY	1	1						
21	2	119836-77830	BOLT, THROUGH	1	1						
22	1	129150-77340	SPACER	1	1						
23	1	26106-081052	BOLT M 8X105 PLATED	1	1						
24	1	26366-080002	NUT M 8	1	1						
25	1	129900-77330	AJUSTER. BELT	1	1						
26	1	26014-080252	BOLT M 8X 25	2	2						

Fig.17.GASKET SET

(A)=4TNE98-SA (D)=
 (B)=4TNE98-G1A (E)=
 (C)= (F)=

17, GASKET SET

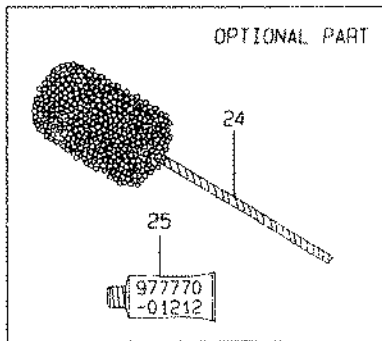
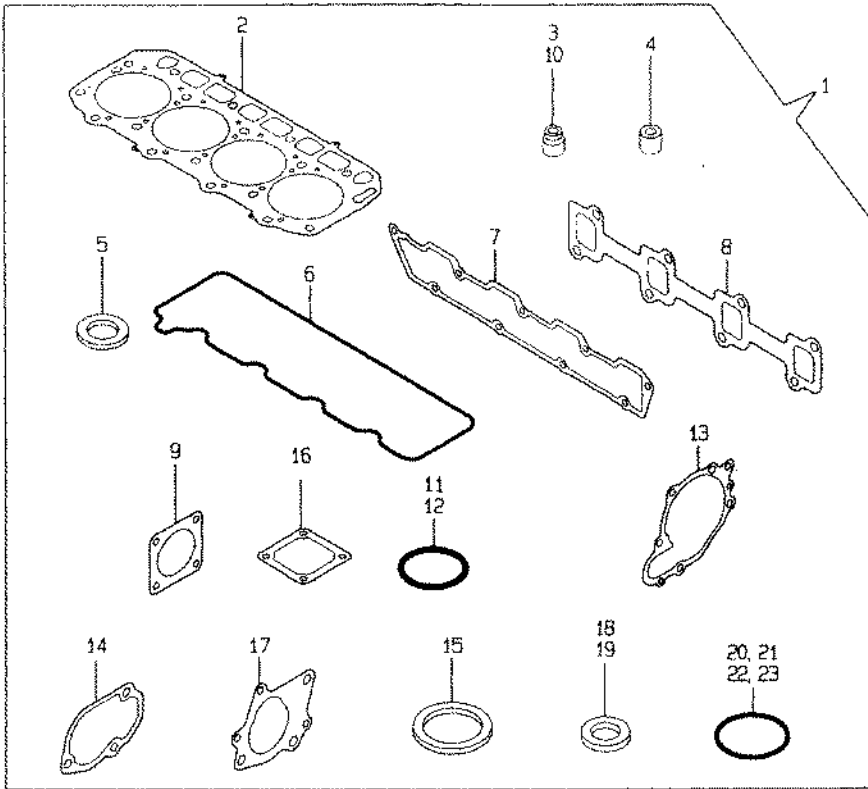

REF	LEV.	PARTS NO.	DESCRIPTION	QTY						
				(A)	(B)	(C)	(D)	(E)	(F)	
1	1	729902-92610	GASKET SET(NON-ASB)	1	1					1
2	2	129902-01330	GASKET,CYL.HEAD	1	1					
3	2	124460-11340	SEAL, VALVE STEM	4	4					
4	2	119625-11870	PROTECTOR, NOZZLE	4	4					
5	2	119625-11880	SEAT, NOZZLE	4	4					
6	2	129900-11310	GASKET, BONNET	1	1					
7	2	129900-12050	GASKET, SUC.MANIFOLD	1	1					
8	2	129900-13251	GASKET	1	1					
9	2	129400-13201	GASKET, (NON-ASB.)	1	1					
10	2	121400-11340	SEAL, VALVE STEM	4	4					
11	2	129900-32030	O-RING P20	2	2					
12	2	129900-32040	O-RING P14	1	1					
13	2	129900-42020	GASKET, CW-P	1	1					
14	2	129900-49830	GASKET, CASE	1	1					
15	2	121850-49550	GASKET, THERMOSTAT	1	1					
16	2	121850-77021	GASKET, (NON-ASB.)	1	1					
17	2	129900-49540	GASKET, THERMOSTAT	1	1					
18	2	23414-080000	GASKET 8, ROUND	7	7					
19	2	124465-44950	GASKET 16	2	2					
20	2	24311-000070	O-RING 1A P-7.0	1	1					
21	2	24311-000120	O-RING 1A P 12.0	3	3					
22	2	24341-000240	O-RING 1A S-24.0	1	1					
23	2	24311-000320	O-RING 1A P-32.0	3	3					
24	1	129400-92420	FLEX HORN	1	1					1
25	1	977770-01212	GASKET, LIQUID	1	1					1

Remarks
 (1) OPTIONAL PART

Fig. 18.GOVERNOR

18. GOVERNOR

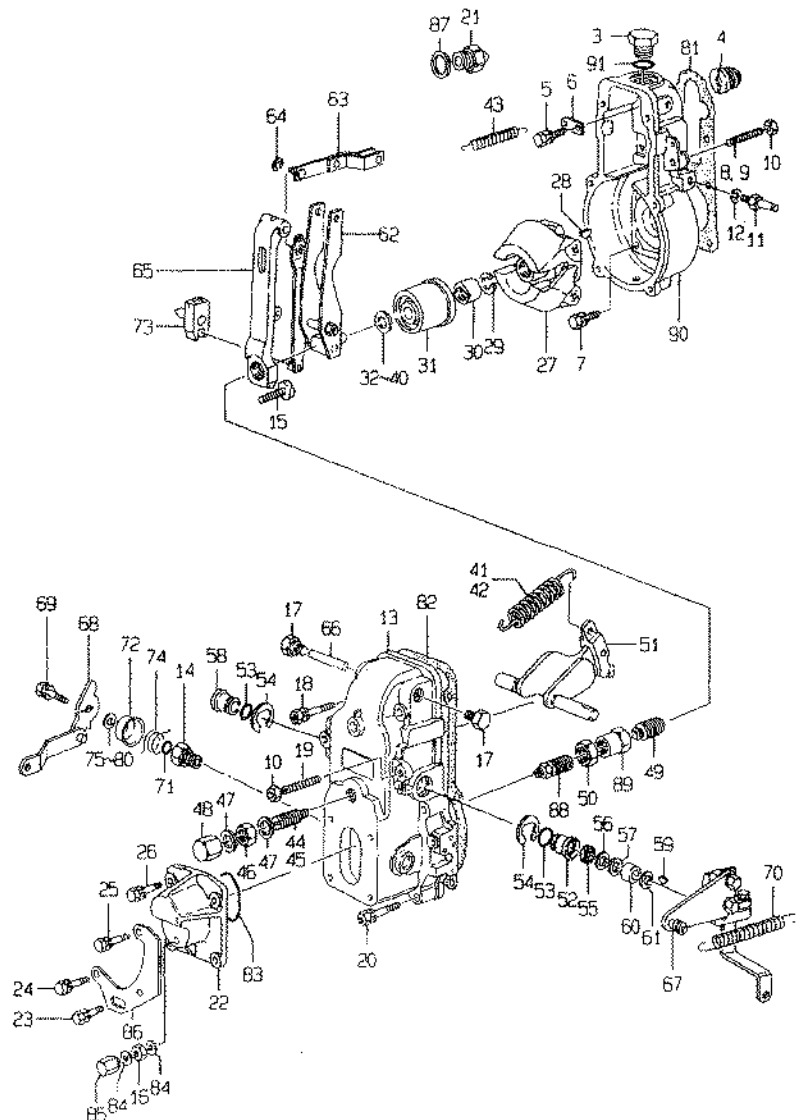

Remarks
 * THIS FIGURE(GOVERNOR ASSY)IS
 INCORPORATED IN THE FUEL INJECTION
 PUMP ASSY(FIG.11)

(A)=4TNE98-SA (D)=
 (B)=4TNE98-G1A (E)=
 (C)= (F)=

REF	LEV	PARTS NO	DESCRIPTION	QTY					
				(A)	(B)	(C)	(D)	(E)	(F)
3	2	X1540072900	PLUG	1	1				
4	2	X1540070200	ADAPTOR	1	1				
5	2	X0200181840	BOLT	1	1				
6	2	X1543501900	PLATE	1	1				
7	2	X0290106810	BOLT	6	6				
8	2	X1540100100	SCREW	1					
9	2	X1540101100	SCREW				1	1	
10	2	X1540110100	NUT	2	2				
11	2	X1540132320	BOLT	1	1				
12	2	X0141108440	SPRING WASHER	1	1				
13	2	X1545001020	COVER	1	1				
14	2	X1543210400	BUSH	1	1				
15	2	X1540313000	SCREW	1	1				
16	2	X1392060600	NUT	1	1				
17	2	X1540360300	PLUG	2	2				
18	2	X0201065040	BOLT	2	2				
19	2	X1540100200	SCREW	1	1				
20	2	X0201063840	BOLT	4	4				
21	2	X1530205220	LIMITER	1	1				
22	2	X1540635100	COVER	1	1				
23	2	X0290206260	BOLT	1	1				
24	2	X0290206260	BOLT	1	1				
25	2	X0200062040	BOLT	1	1				
26	2	X0200061640	BOLT	1	1				
27	2	X1541010020	FLYWAIGHT ASSY.	1	1				
28	2	X0258031610	WOODRUFF KEY	1	1				
29	2	X0293212020	SPRING WASHER	1	1				
30	2	X0292312030	NUT	1	1				
31	2	X1541230120	SLEEVE	1	1				
32	2	X0293110010	SHIM	1	1				
33	2	X0293110180	SHIM	1	1				
34	2	X0293110190	SHIM	1	1				
35	2	X0293110210	SHIM	1	1				
36	2	X1394100000	SHIM	1	1				
37	2	X1394100100	SHIM	1	1				
38	2	X1394103000	SHIM	1	1				
39	2	X1394103100	SHIM	1	1				
40	2	X1394103200	SHIM	1	1				
41	2	X1541502900	SPRING	1					
42	2	X1541500100	SPRING		1				
43	2	X1541540701	SPRING	1	1				
44	2	X1541580920	CAPSULE, SPRING	1					
45	2	X1541581820	CAPSULE, SPRING				1	1	
46	2	X1540111700	NUT	1	1				
47	2	X0265121540	GASKET	2	2				
48	2	X1541591200	NUT, CAP	1	1				
49	2	X1541856120	SPRING	1					
50	2	X0292016080	NUT	1					
51	2	X1542006920	LEVER	1	1				
52	2	X1542043000	BUSH	1	1				
53	2	X0296318020	O-RING	2	2				
54	2	X0160101640	RING, SNAP	2	2				
55	2	X1396110000	SEAL, OIL	1	1				
56	2	X1394110000	SHIM	1	1				

** CONTINUE **

(A)=4TNE98-SA (D)=
 (B)=4TNE98-G1A (E)=
 (C)= (F)=

18. GOVERNOR

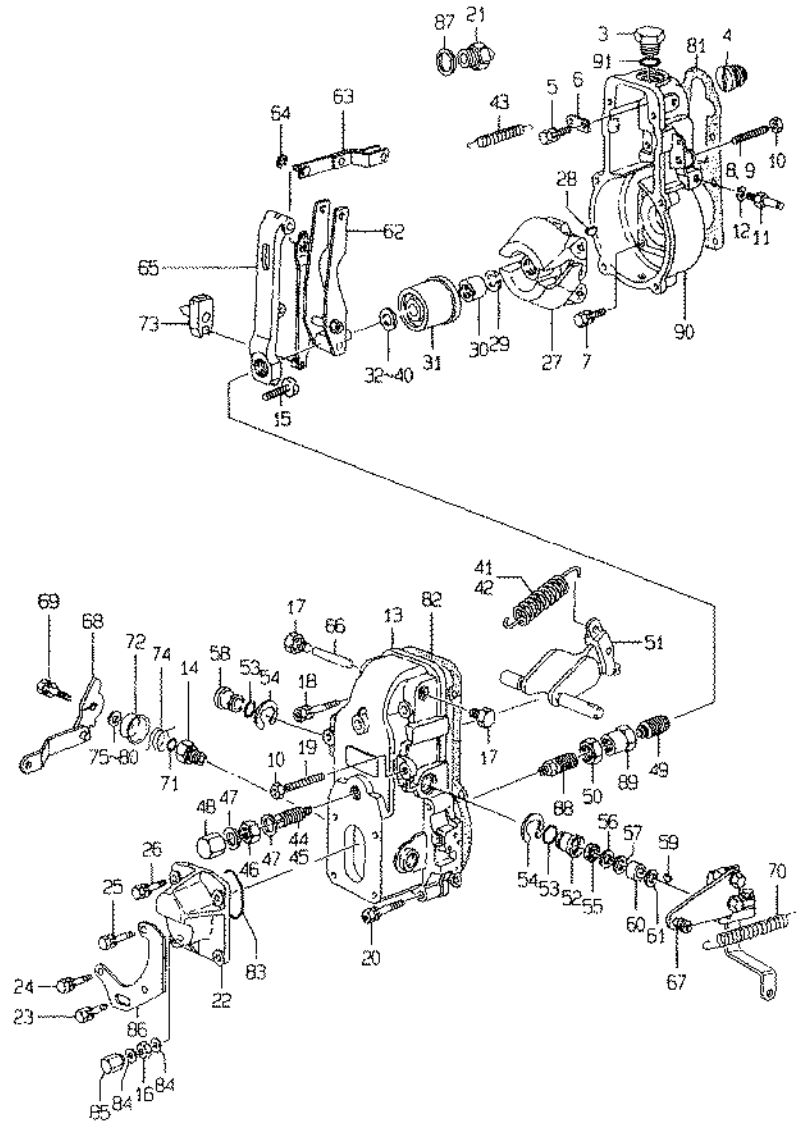

REF	LEV.	PARTS NO	DESCRIPTION	Q'TY					
				(A)	(B)	(C)	(D)	(E)	(F)
57	2	X0293111070	SHIM	1	1				
58	2	X1542043100	BUSH	1	1				
59	2	X0258031310	WOODRUFF KEY	1	1				
60	2	X1542062800	COLLAR	1	1				
61	2	X1542060200	WASHER	1	1				
62	2	X1542163820	LEVER ASSY, GUIDE	1	1				
63	2	X1542303920	LINK	1	1				
64	2	X0160100540	RING, SNAP	1	1				
65	2	X1542364100	LEVER, TENSION	1	1				
66	2	X1542370100	PIN	1	1				
67	2	X1543956420	LEVER	1	1				
68	2	X1543829320	LEVER	1	1				
69	2	X0200061640	BOLT	1	1				
70	2	X1543142600	SPRING	1	1				
71	2	X0296310030	O-RING	1	1				
72	2	X1543220100	CAP	1	1				
73	2	X1543265020	LEVER ASSY	1	1				
74	2	X1543277400	SPRING	1	1				
75	2	X0293110520	SHIM	1	1				
76	2	X0293110530	SHIM	1	1				
77	2	X0293110540	SHIM	1	1				
78	2	X0293110550	SHIM	1	1				
79	2	X0293110560	SHIM	1	1				
80	2	X0293110570	SHIM	1	1				
81	2	X1543507700	GASKET	1	1				
82	2	X1543507800	GASKET	1	1				
83	2	X0296352020	O-RING	1	1				
84	2	X0265061040	GASKET	2	2				
85	2	X1540351600	CAP NUT	1	1				
86	2	X1543567200	BRACKET	1	1				
87	2	X0265182240	GASKET	1	1				
88	2	X1541883320	SPRING	1	1				
89	2	X0292016010	NUT	1	1				
90	2	X1540006400	FLANGED HOUSING	1	1				
91	2	X0296325070	O-RING	1	1				

Remarks
 * THIS FIGURE(GOVERNOR ASSY)IS
 INCORPORATED IN THE FUEL INJECTION
 PUMP ASSY(FIG.11).

Fig.19.FEED PUMP

(A)=4TNE98-SA (D)=
 (B)=4TNE98-G1A (E)=
 (C)= (F)=

19.FEED PUMP

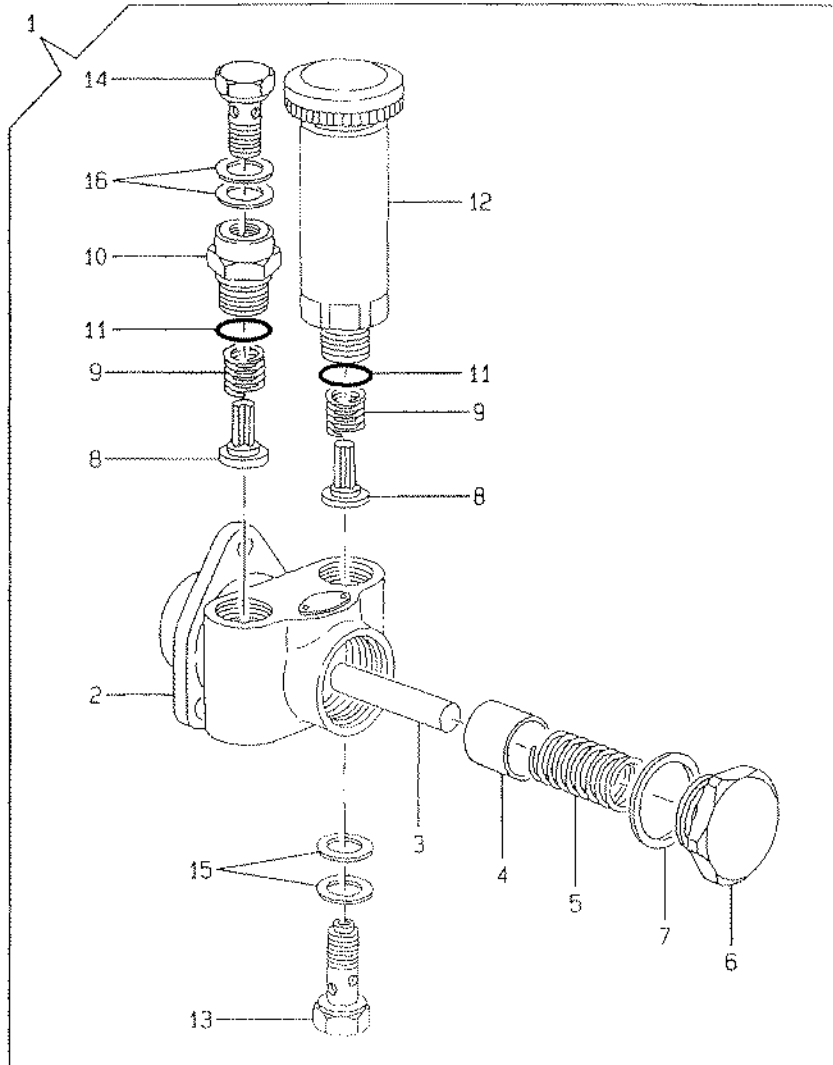

REF	LEV	PARTS NO	DESCRIPTION	Q'TY						
				(A)	(B)	(C)	(D)	(E)	(F)	
1	2	129900-52010	PUMP ASSY.FUEL FEED	1	1					
2	3	X1520620020	HOUSING	1	1					
3	3	X1520300200	ROD. PUSH	1	1					
4	3	X1521002301	PISTON	1	1					
5	3	X1521020400	SPRING	1	1					
6	3	X1521051500	PLUG	1	1					
7	3	X1395260000	GASKET	1	1					
8	3	X1521150500	VALVE	2	2					
9	3	X1521160200	SPRING	2	2					
10	3	X1521180900	ADAPTER	1	1					
11	3	X0296316060	O-RING	2	2					
12	3	X1522006720	PRIMING PUMP	1	1					
13	3	X1523005920	BOLT	1	1					
14	3	X0297314680	EYE BOLT	1	1					
15	3	X0265141840	GASKET	2	2					
16	3	X0265141840	GASKET	2	2					

Remarks
 THIS FIGURE(FEED PUMP ASSY)IS
 INCORPORATED IN THE FUEL INJECTION
 PUMP ASSY(FIG.11).